

The patented 90° **2590SSV** angle tool with slide valve control and front exhaust is designed with the turbine in its angle head and no gears. This design results in light weight with low heat and low vibration.

Excellent for deburring and finishing. High rotational speed is maintained by our patented governed turbines so you simply guide the 2590 letting speed do the work with just a light hand.

Just 2 moving parts in this tool for super reliability and the 2590 is both maintenance-free and totally oil free. Select governed 30,000 or 40,000 rpm.

Dimensions

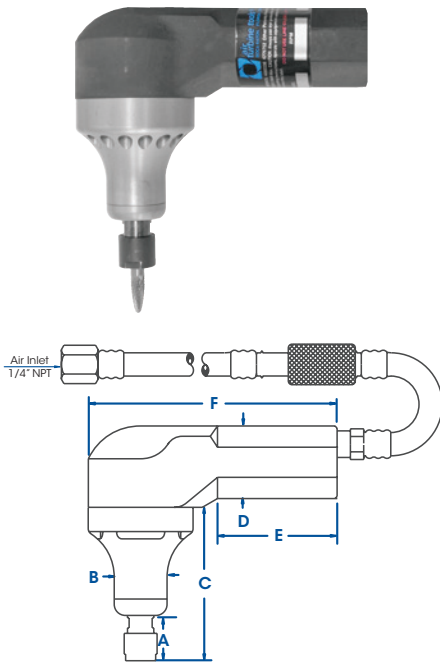

A	0.86" (21.84mm)	C	2.90" (73.66mm)	E	2.25" (57.15mm)
B	1.00" (25.40mm)	D	1.37" (34.80mm)	F	4.63" (117.60mm)

2590SSV Series

1/4"		6mm	
Speed RPM	Part #	Speed RPM	Part #
30,000	35846	30,000	35847
40,000	35848	40,000	35849

Accessories

Model	Part #
High Flow Filter	30004
High Flow Filter / Regulator	30003
High Flow Filter / Regulator / Extractor	30008
5' Air Supply Assembly w/Fitting for SV Models	34207

Standard Equipment

Hand Tool, 1/4" or optional 6mm collet, collet wrenches, front exhaust. 5' air supply assembly with slide valve and 1/4" NPT air supply fitting.

Oil free 90 psi / 6.2 bar, clean, dry air supply required.

General Specifications

2590SSV

Speed RPM	30,000 / 40,000
Power Rating hp (kW)	0.4 (0.30) / 0.45 (0.34)
Inlet Air Pressure	90 PSI (6.2 Bar)
Air Consumption Idle cfm (l/s)	10 (4.72) / 13 (6.14)
Air Consumption Working Flow cfm (l/s)	11 (5.19) - 20 (9.44)
Sound Level	Less Than 67 dBA
Max Shank Capacity	1/4" (6mm)
Hand Tool Weight	15.2oz (0.43kg)

Vibration Statistics

Time to reach EAV 2.5 m/s² A(8)
64 hours, 11 minutes

Time to reach ELV 5 m/s² A(8)
256 hours, 41 minutes

Vibration magnitude m/s² r.m.s
0.88

Tel: +1.561.994.0500 • Fax: +1.561.994.8097 • www.airturbinetools.com • info@airturbinetools.com

Do not use couplings/hoses less than 1/4" / 6mm Internal Diameter (ID). With 230, 525X, and 3090 units use a minimum 3/8" / 9.5mm ID coupling/hose. For 230X units use a minimum 10mm ID coupling/hose. Always use a 5 micron filter and/or extractor where required and check specified PSI or L/S air flow. Use 6.2 Bar / 90 psi clean, dry, oil-free air only. Use eye protection and follow safety instructions. Supply is subject to Air Turbine Technology Inc. (ATT) distributor policies and upon terms contained in the ATT distributor agreement. Subject to availability, change of specifications, price and terms without notice. All specifications approximate.
© 2014 Air Turbine Technology, Inc. All rights reserved.