

For Polishing, Sanding, Deburring the **2590SVR** tool has a slide valve control, rear exhaust and a head angled at 90°. Speeds available are 30,000 RPM and 40,000 RPM. Well-balanced and easy-to-use, this tool is gearless and has no moving parts in the handle. The **2590SVR** has a rear exhaust. Powerful, yet light weight, the **2590SVR** accelerates deburring and finishing in hard-to-reach applications and can be used with appropriately sized quick change disks. 1/4" and 6 mm standard collet capacity - other optional collets available.

Model 2590SVR

0.45 hp
0.34kW

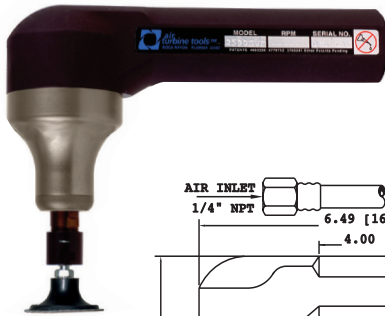

Max. Abrasive Disc Diameter = 2" (50.80mm)

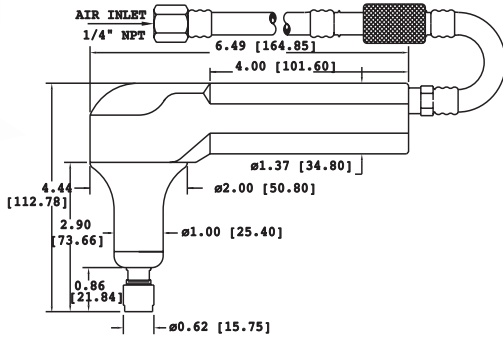



1/4"	No Brake
Speed	Part #
30,000 rpm	35830
40,000 rpm	35840

6mm	No Brake
Speed	Part #
30,000 rpm	35831
40,000 rpm	35841

Weight: 18 oz / .5 kg

Standard Equipment Included: 1/4" or optional 6mm collet, collet wrenches, rear exhaust 5' air supply assembly with slide valve and 1/4" NPT air supply fitting. Oil free 90 psi / 6.2 bar dry, clean air supply required.

General Specifications	2590SVR  	
	Speed RPM	30,000
Power Rating HP (KW)	.4 (.30)	.45 (.34)
Inlet Air Pressure	90 PSI (6.2 Bar)	
Air Consumption-Idle cfm (L/s)	10 (4.72)	13 (6.14)
Air Consumption-Stall Flow cfm (L/s)	11 (5.19) - 20 (9.44)	
TIR Collet Held Shank	Less than .001" (.03mm)	
Sound Level	Less than 67dBa	
Standard Shank Capacity	1/4" (6mm)	

Accessories

	Part#
High Flow Filter	30004
High Flow Filter / Regulator	30003
Collet Guard	30072
Foot Pedal Control	30030

