

For Polishing, Sanding, Deburring the **2590SVF** Model has a slide valve control, front air exhaust and a head angled at 90°. Collet capacities of 1/4" or 6mm; speed ranges of 30,000 RPM and 40,000 RPM for fast and finer finishing, with several optional collets for smaller and metric applications. Well-balanced and easy-to-use, these tools are gearless and have no moving parts in the handle. The **2590SVF** has a front exhaust that keeps the work area clear of debris. Powerful yet light weight, the **2590SVF** accelerates deburring and finishing in hard-to-reach applications, light weight with low vibration.

Model 2590SVF

0.45 hp
0.34 kW

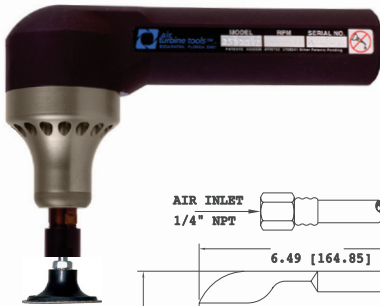

Max. Abrasive Disc Diameter = 2" (50.80mm)

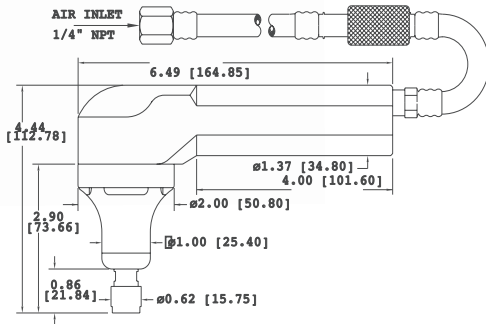



1/4"	No Brake
Speed	Part #
30,000 rpm	35832
40,000 rpm	35842

6mm	No Brake
Speed	Part #
30,000 rpm	35833
40,000 rpm	35843

Weight: 18 oz / .5 kg

Standard Equipment Included: 1/4" or optional 6mm collet, collet wrenches, rear exhaust, 5' air supply assembly with slide valve and 1/4" NPT air supply fitting. Oil free 90 psi / 6.2 bar dry, clean air supply required.

General Specifications	 2590SVF 	
	Speed RPM	30,000
Power Rating HP (KW)	.4 (.30)	.45 (.34)
Inlet Air Pressure	90 PSI (6.2 Bar)	
Air Consumption-Idle cfm (L/s)	10 (4.72)	13 (6.14)
Air Consumption-Working cfm (L/s)	11 (5.19) - 20 (9.44)	
TIR Collet Held Shank	Less than .001" (.03mm)	
Sound Level	Less than 67dBa	
Standard Shank Capacity	1/4" (6mm)	

Accessories

Accessories	Part#
High Flow Filter	30004
High Flow Filter / Regulator	30003
Collet Guard	30072
Foot Pedal Control	30030

