

From de-burring to finishing, the **2545DMF** increases production rates and reduces repairs, fatigue and injury. With no gears the **2545DMF** tool has a head angled at 45° for comfort and easy access. The **2545DMF** can perform tasks such as grinding, deburring and polishing. Standard collet capacities of 1/4" or 6mm. These tools are gearless and have no moving parts in the handle. Result - a lighter tool with greater reliability! The **2545SVF** has a front exhaust to help keep the work area clear of debris and the trigger switch (DM) gives instant control. No maintenance or added lubrication.

Model 2545DMF

0.45 hp
0.34 kW



Max. Abrasive Disc Diameter = 2" (50.80mm)

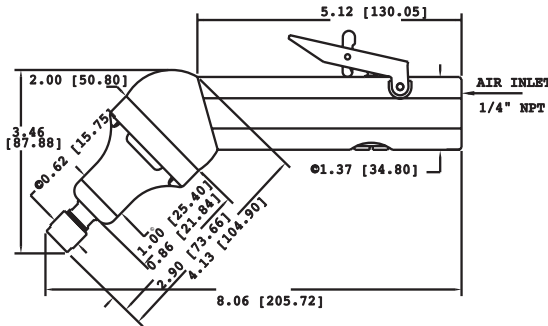



1/4"	No Brake	With Brake
Speed	Part #	Part #
30,000 rpm	35534	35634
40,000 rpm	35544	35644

6mm	No Brake	With Brake
Speed	Part #	Part #
30,000 rpm	35535	35635
40,000 rpm	35545	35645

Weight: 20 oz / .56 kg

Standard Equipment Included: 1/4" or optional 6mm collet, collet wrenches, rear exhaust trigger switch and 1/4" NPT air supply fitting. Oil free 90 psi / 6.2 bar dry, clean air supply required. **Optional collets page 49.**

General Specifications	 2545DMF 	
Speed RPM	30,000	40,000
Power Rating HP (KW)	.4 (.30)	.45 (.34)
Inlet Air Pressure	90 PSI (6.2 Bar)	
Air Consumption-Idle cfm (L/s)	10 (4.72)	13 (6.14)
Air Consumption-Working cfm (L/s)	11 (5.19) - 20 (9.44)	
TIR Collet Held Shank	Less than .001" (.03mm)	
Sound Level	Less than 67dBa	
Standard Shank Capacity	1/4" (6mm)	

Accessories

Accessories	Part#
High Flow Filter	30004
High Flow Filter / Regulator	30003
Collet Guard	30072
5' Air Supply Assembly	30010

